

BELLOW CUPS WITH MALE AND FEMALE SUPPORTS

The BELLOW CUPS described in these pages have been specially designed for handling baked goods, such as biscuits, bread, pizza, etc., as well as plastic or paper bags containing chocolates, sweets, pasta, flour, powder, etc. Thanks to their great flexibility, they can also be used to compensate flatness errors or for gripping on inclined surfaces. Their anodised aluminium supports are provided with a threaded male or female central pin to allow suction and to fasten it to the machine. The cups can be assembled onto them with no adhesives. For the spare part, all you have to do is request the cup indicated in the table in the desired compound.

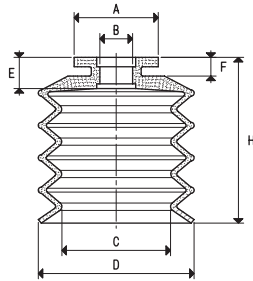

CUPS

Art.	Force Kg	A ∅	B ∅	C ∅	D ∅	E	F	H
01 20 23 *	0.78	14.5	5.0	14	20	5	4	23
01 30 32 *	1.76	20.0	6.5	21	30	7	5	32
01 40 42 *	3.14	20.0	6.5	28	40	7	5	42
01 50 53 *	4.90	27.0	10.5	35	50	10	6	53

* Complete the code indicating the compound: A= oil-resistant rubber; N= natural para rubber; S= silicon

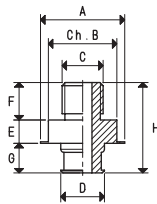

MALE SUPPORTS

Art.	A ∅	B	C ∅	D ∅	E	F	G	H	Support material	Cup art.	Weight g
00 08 133	14.5	13	G1/8"	8.5	5.5	8	5.0	18.5	aluminium	01 20 23	3.5
00 08 135	20.0	17	G1/4"	10.0	7.5	12	7.5	27.0	aluminium	01 30 32 01 40 42	9.5
00 08 142	27.0	22	G1/4"	14.0	7.5	12	9.5	29.0	aluminium	01 50 53	15.7

3D drawings available at www.vuototecnica.net

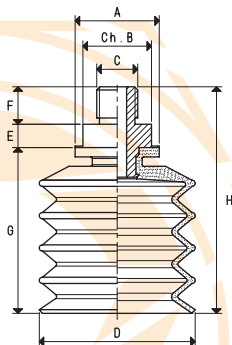

CUPS WITH MALE SUPPORTS

Art.	Force Kg	A ∅	B	C ∅	D ∅	E	F	G	H	Cup Art.	Support Art.	Weight g
08 20 23 *	0.78	14.5	13	G1/8"	20	5.5	8	23	36.5	01 20 23	00 08 133	5.3
08 30 32 *	1.76	20.0	17	G1/4"	30	7.5	12	32	51.5	01 30 32	00 08 135	15.1
08 40 42 *	3.14	20.0	17	G1/4"	40	7.5	12	42	61.5	01 40 42	00 08 135	21.1
08 50 53 *	4.90	27.0	22	G1/4"	50	7.5	12	53	72.5	01 50 53	00 08 142	40.1

* Complete the code indicating the compound: A= oil-resistant rubber; N= natural para rubber; S= silicon

BELLOW CUPS WITH FEMALE SUPPORTS



CUPS

Art.	Force Kg	A ∅	B ∅	C ∅	D ∅	E	F	H
01 20 23 *	0.78	14.5	5.0	14	20	5	4	23
01 30 32 *	1.76	20.0	6.5	21	30	7	5	32
01 40 42 *	3.14	20.0	6.5	28	40	7	5	42
01 50 53 *	4.90	27.0	10.5	35	50	10	6	53

* Complete the code indicating the compound: A= oil-resistant rubber; N= natural para rubber; S= silicon

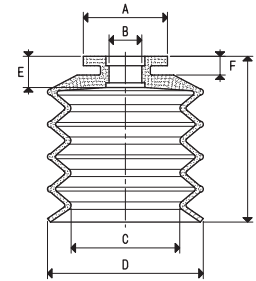

FEMALE SUPPORTS

Art.	A ∅	B	C ∅	D ∅	E	F	G	H	Support material	Cup art.	Weight g
00 08 132	14.5	13	G1/8"	8.5	12	8	5.0	17.0	aluminium	01 20 23	3.8
00 08 134	20.0	17	G1/4"	10.0	14	10	7.5	21.5	aluminium	01 30 32 01 40 42	8.3
00 08 141	27.0	22	G1/4"	14.0	14	10	9.5	23.5	aluminium	01 50 53	19.7

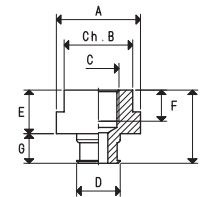

CUPS WITH FEMALE SUPPORT

Art.	Force Kg	A ∅	B	C ∅	D ∅	E	F	G	H	Cup Art.	Support Art.	Weight g
08 20 23 F *	0.78	14.5	13	G1/8"	20	12	8	23	35	01 20 23	00 08 132	5.6
08 30 32 F *	1.76	20.0	17	G1/4"	30	14	10	32	46	01 30 32	00 08 134	13.9
08 40 42 F *	3.14	20.0	17	G1/4"	40	14	10	42	56	01 40 42	00 08 134	19.9
08 50 53 F *	4.90	27.0	22	G1/4"	50	14	10	53	67	01 50 53	00 08 141	44.1

* Complete the code indicating the compound: A= oil-resistant rubber; N= natural para rubber; S= silicon

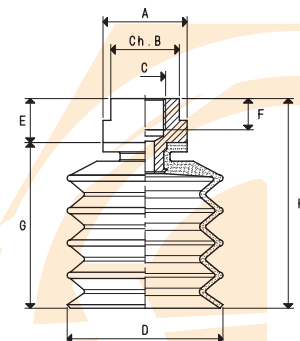

3D drawings available at www.vuototecnica.net

Conversion ratio: inch = $\frac{mm}{25.4}$; pounds = $\frac{g}{453.6}$ = $\frac{Kg}{0.4536}$

GAS - NPT thread adapters available at page 1.117